

Number of modules x 1000 + 1027
e.g. 5 modules = 6027

29cm quadro truss covered with black or white lycra sleeves

Textured stainless steel plates

All vertical walls: Stainless steel covered with black or white sticky foil

Black or blue mats reducing splashes

Lighting

2 or more 230VAC black cables 8m long
Standard european CEE7/7 plug

Pump always installed on the left side of the installation

Construction height: 2002 - 6002, rounded to 500
e.g. 4002

COMPANY:  Wordfall Ul. Szczygłów 30 44-200 Rybnik		DO NOT SCALE DRAWING		REVISION	
		TITLE: Water screen for interior use			
		PART NO: WFL-KK-A0001-7			
		DESCRIPTION: Mobile Installation			
MATERIAL:	SURFACE FINISH	THICKNESS: mm	BEND RADIUS: mm	WEIGHT: g	A3
		SCALE: 1:30		SHEET 1 OF 19	

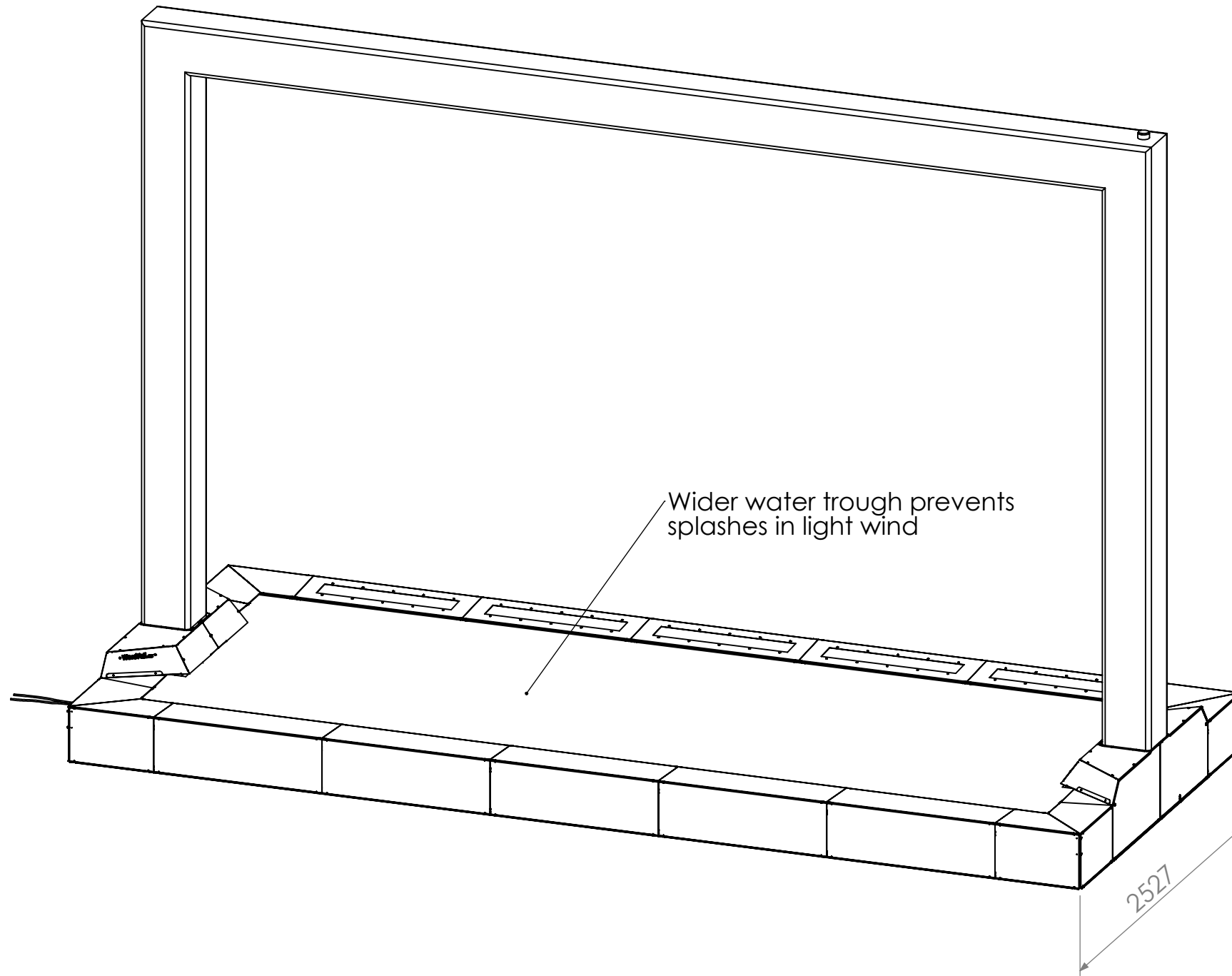

COMPANY:  Wordfall Ul. Szczygłów 30 44-200 Rybnik		DO NOT SCALE DRAWING		REVISION	
		TITLE Water screen for exterior use			
		PART NO WFL-KK-A0001-8			
		DESCRIPTION Mobile Installation			
DRAWN	Wordfall	TEL.	+48601296649		
CHK'D	Wordfall				
APPV'D					
MATERIAL:	SURFACE FINISH		THICKNESS	BEND RADIUS	WEIGHT
			mm	mm	g
			SCALE:1:30		A3
			SHEET 2 OF 19		

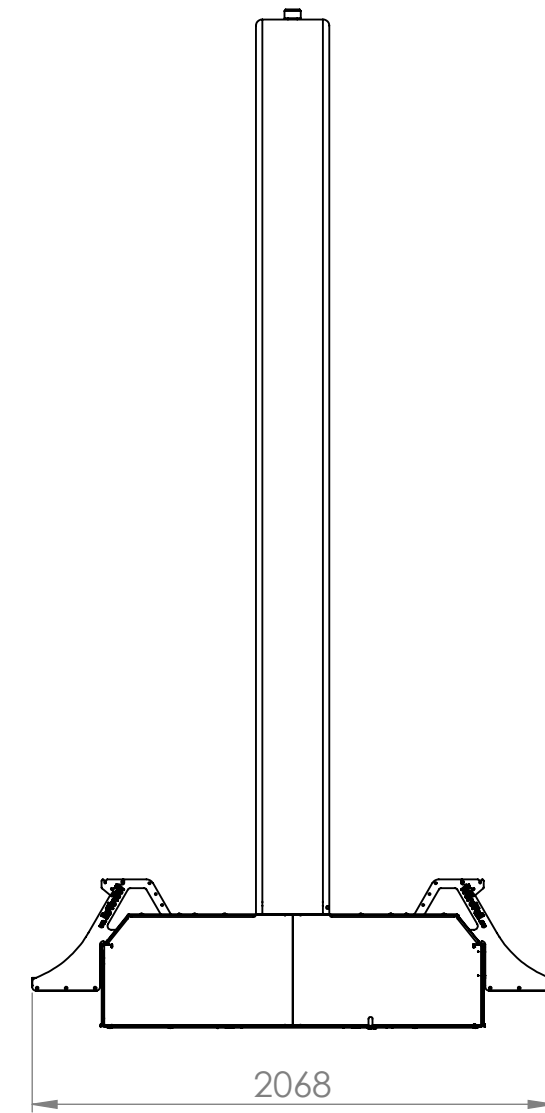
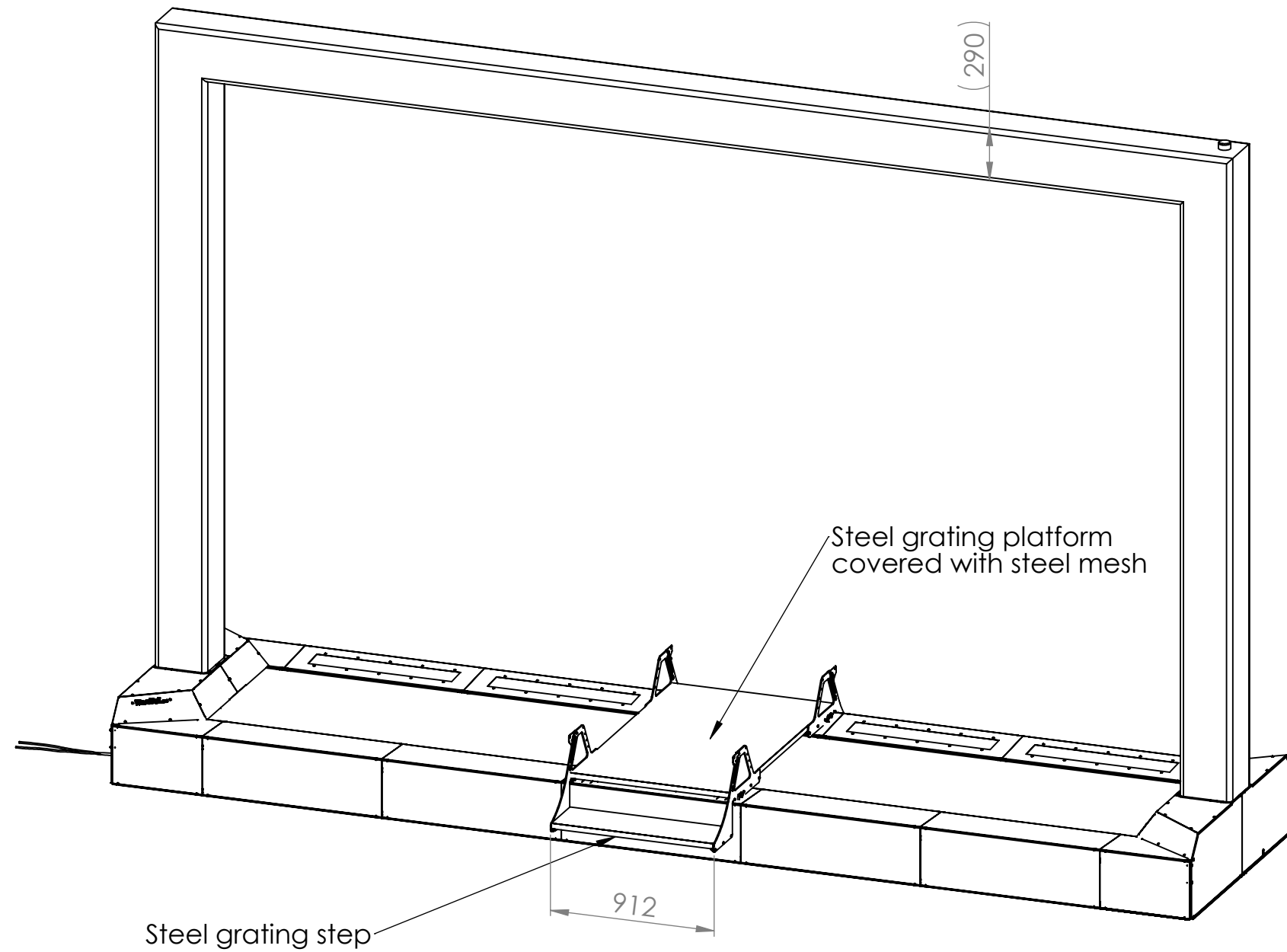

The water stops falling when people step on the platform

COMPANY:  Wordfall Ul. Szczygłów 30 44-200 Rybnik		DO NOT SCALE DRAWING		REVISION	
DRAWN: Wordfall		TEL: +48601296649		TITLE: Platform for interior use	
CHK'D: Wordfall		APPV'D:		PART NO: WFL-KK-A0001-13	
MATERIAL:		SURFACE FINISH:		DESCRIPTION: Mobile Installation	
THICKNESS: mm		BEND RADIUS: mm		WEIGHT: g	
SCALE: 1:30		SHEET 3 OF 19		A3	

8

7

6

5

4

3

2

1

F

F

E

E

D

D

C

C

B

B

A

A

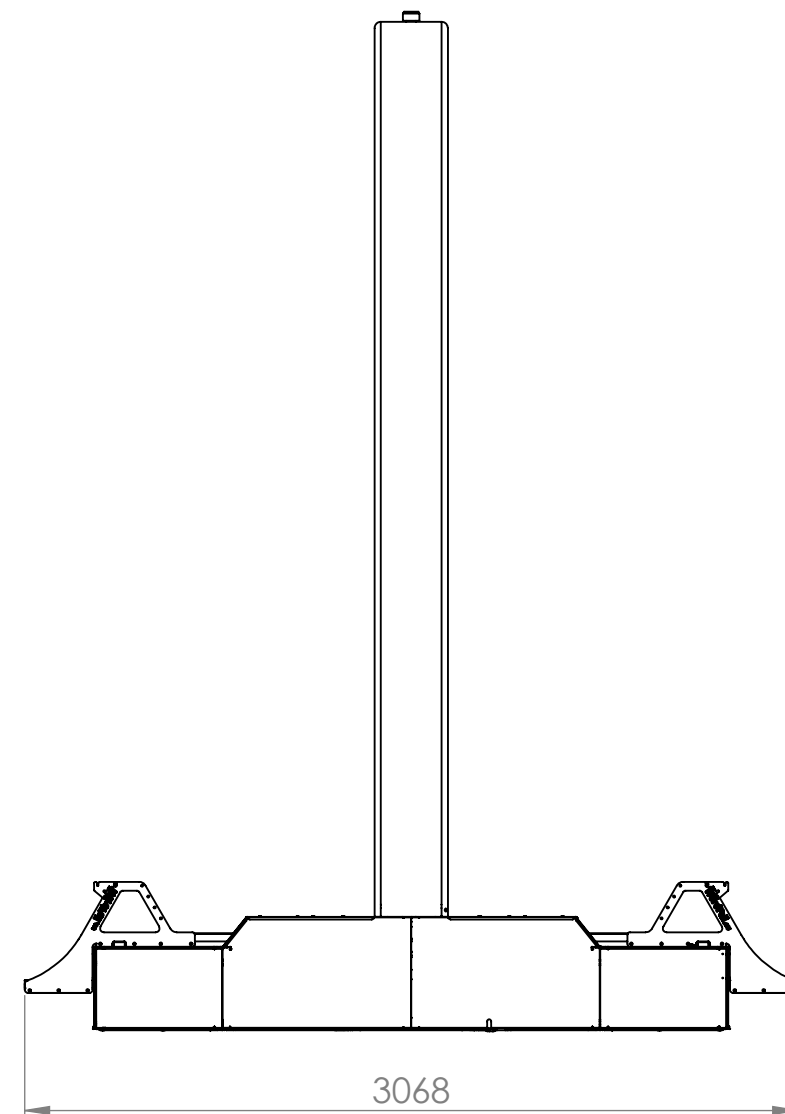
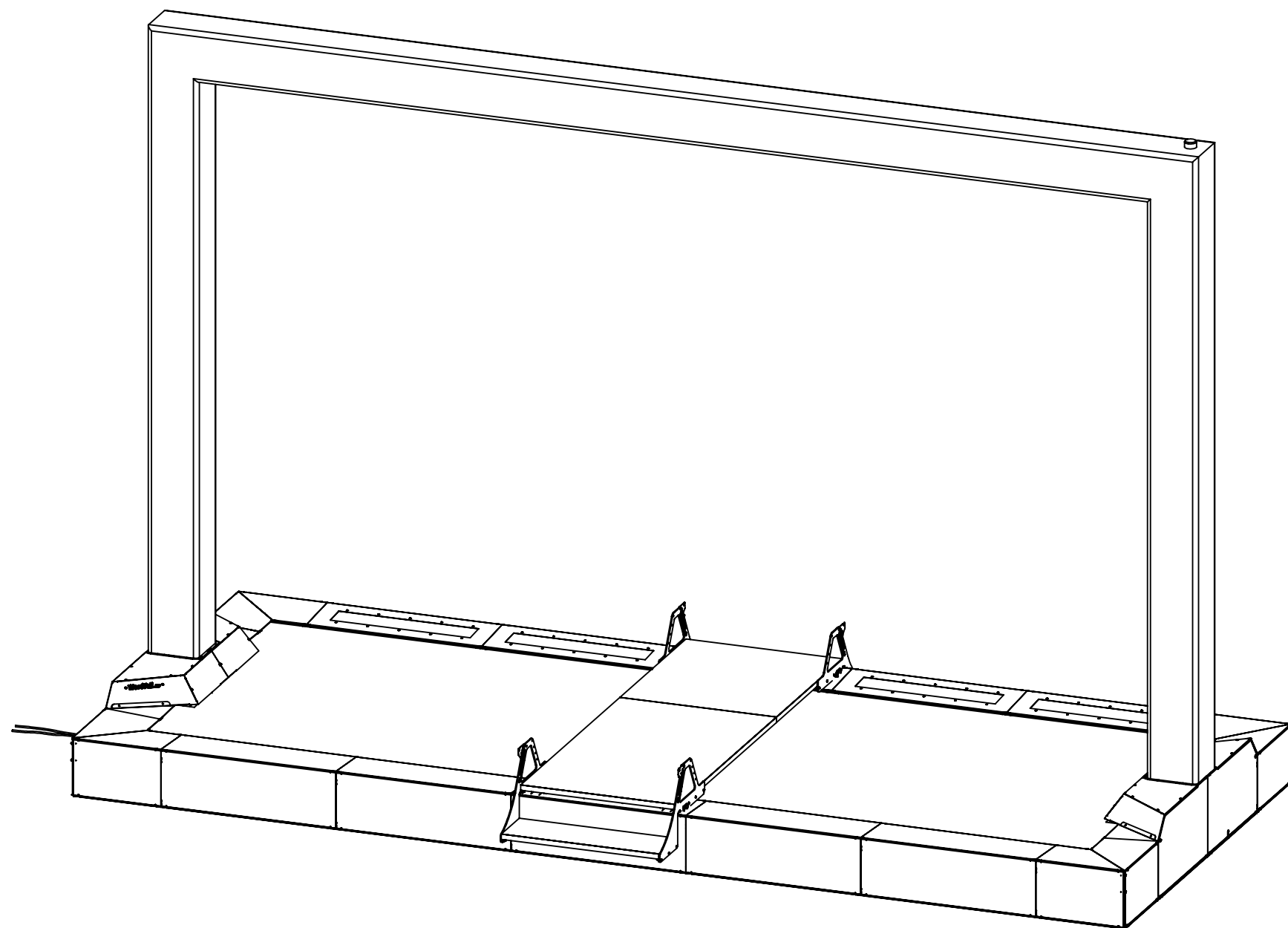

COMPANY:  Wordfall Ul. Szczygłów 30 44-200 Rybnik		DO NOT SCALE DRAWING		REVISION	
		TITLE Platform for exterior use			
		PART NO WFL-KK-A0001-14			
		DESCRIPTION Mobile Installation			
MATERIAL:	SURFACE FINISH	THICKNESS mm	BEND RADIUS mm	WEIGHT g	A3
		SCALE:1:30		SHEET 4 OF 19	

8

7

6

5

4

3

2

1

8

7

6

5

4

3

2

1

F

F

E

E

D

D

C

C

B

B

A

A

Total height:
 -3820mm
 -4320mm
 -4820mm
 -5320mm

300l IBC tank
 (provided by client)

Swing with a position
 sensor

1000

618

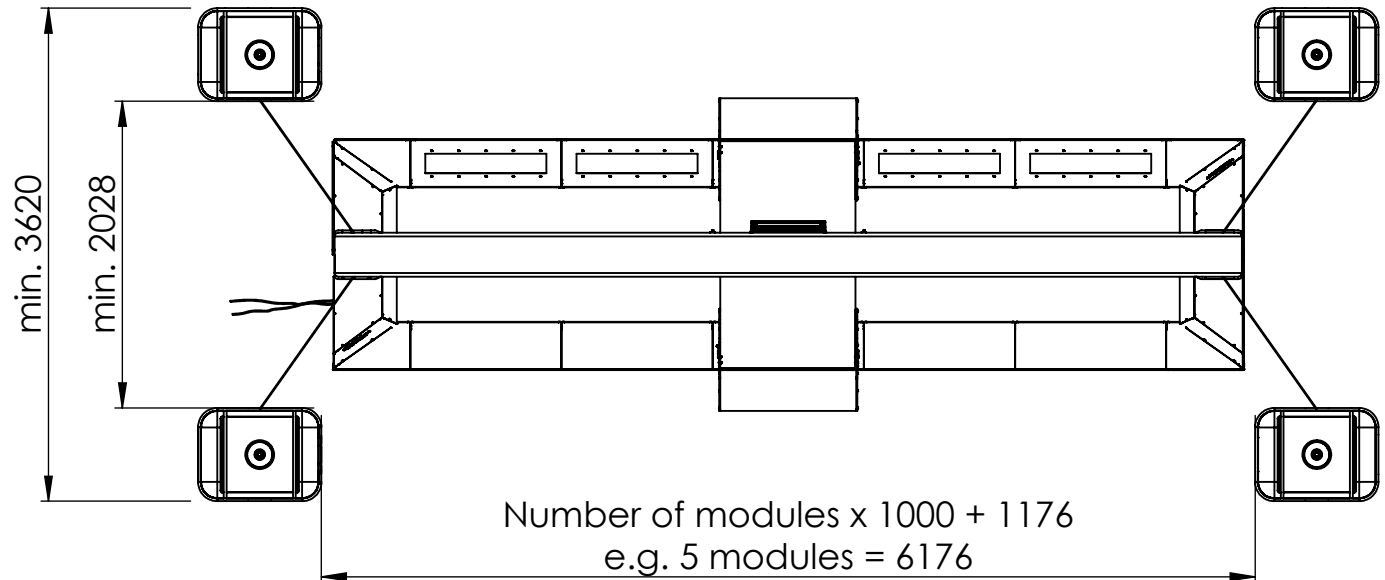

COMPANY:  Wordfall Ul. Szczygłów 30 44-200 Rybnik		DO NOT SCALE DRAWING		REVISION	
DRAWN: Wordfall		TEL: +48601296649		TITLE: Swing for interior use	
CHK'D: Wordfall		APPV'D:		PART NO: WFL-KK-A0001-9	
MATERIAL:		SURFACE FINISH:		DESCRIPTION: Mobile Installation	
THICKNESS: mm		BEND RADIUS: mm		WEIGHT: g	
SCALE: 1:30		SHEET 5 OF 19			

8

7

6

5

4

3

2

1

8

7

6

5

4

3

2

1

F

F

E

E

D

D

C

C

B

B

A

A

Total height:
 -3820mm
 -4320mm
 -4820mm
 -5320mm

600l IBC tank
 (provided by client)

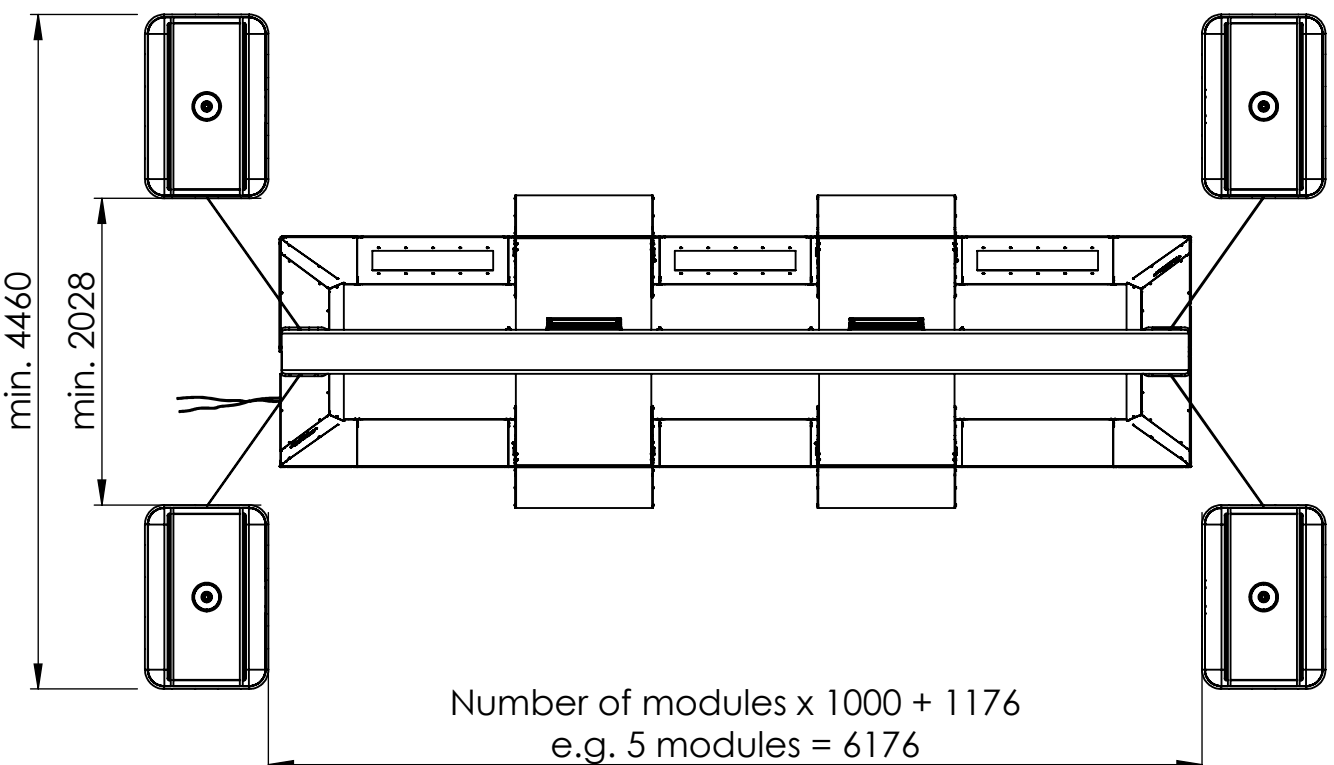
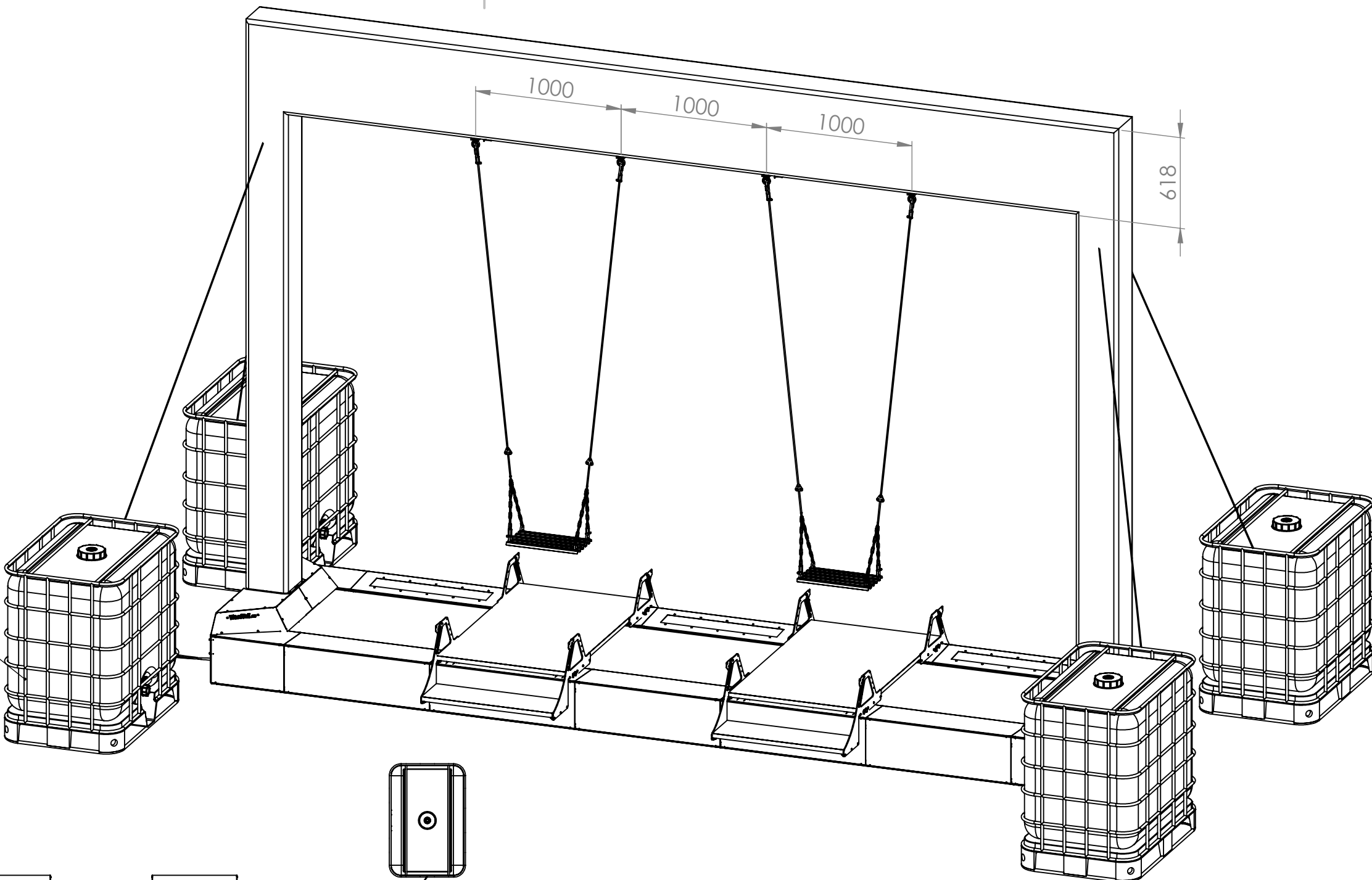

Scale 1:50

COMPANY:  Wordfall Ul. Szczygłów 30 44-200 Rybnik		DO NOT SCALE DRAWING		REVISION	
DRAWN: Wordfall		TEL: +48601296649		TITLE: Two swings for interior use	
CHK'D: Wordfall		APPV'D:		PART NO: WFL-KK-A0001-11	
MATERIAL:		SURFACE FINISH:		DESCRIPTION: Mobile Installation	
THICKNESS: mm		BEND RADIUS: mm		WEIGHT: g	
SCALE: 1:30		SHEET 6 OF 19		A3	

8

7

6

5

4

3

2

1

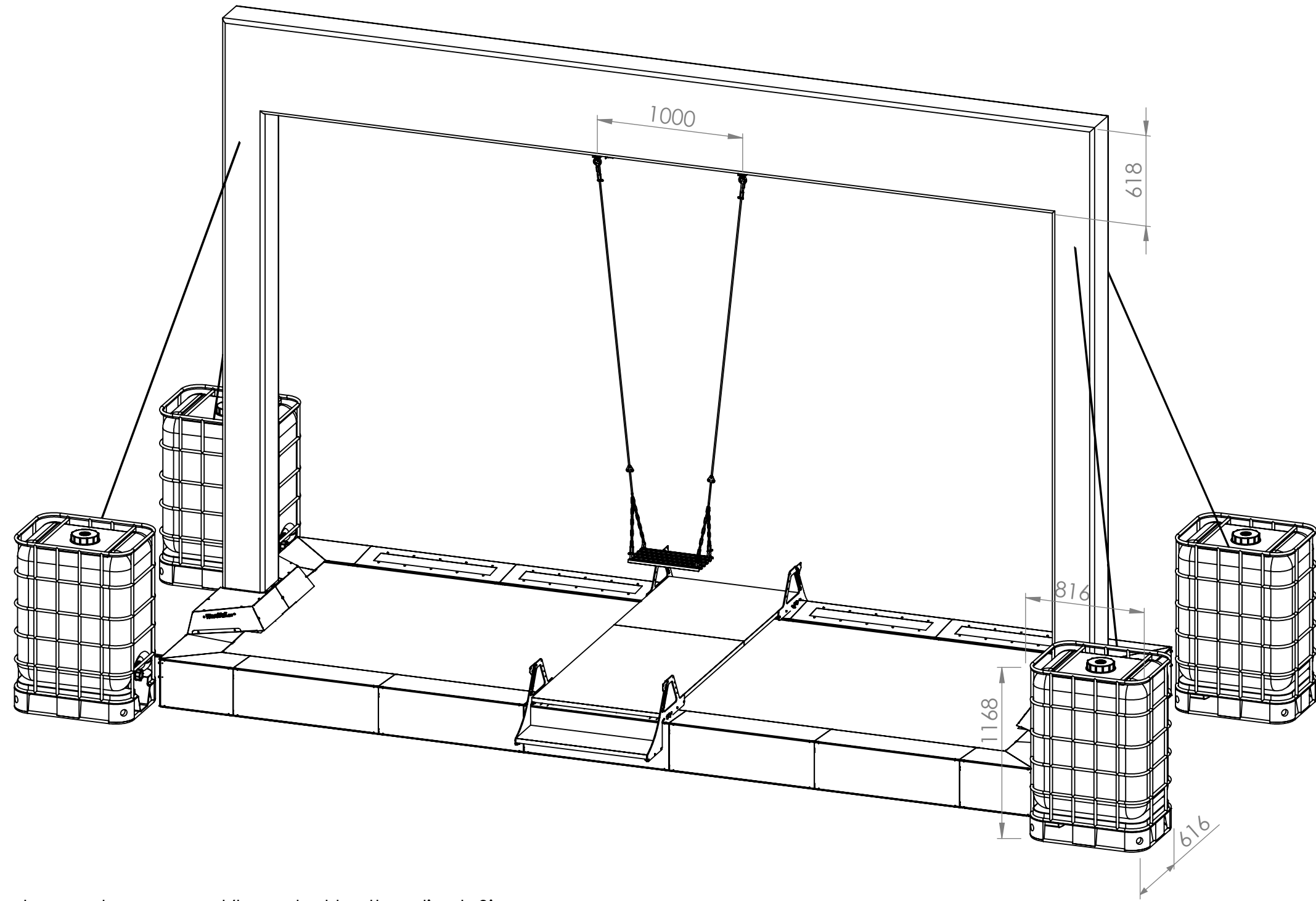

Tanks may be covered/branded by the client. Sizes may vary.

COMPANY:  Wordfall Ul. Szczygłów 30 44-200 Rybnik		DO NOT SCALE DRAWING		REVISION	
DRAWN		NAME		TITLE	
CHK'D		TEL.		Swing for exterior use	
APPV'D		+48601296649		PART NO	
MATERIAL:		SURFACE FINISH		WFL-KK-A0001-10	
				DESCRIPTION	
				Mobile Installation	
		THICKNESS		WEIGHT	
		mm		g	
		BEND RADIUS		A3	
		mm			
		SCALE:1:30		SHEET 7 OF 19	

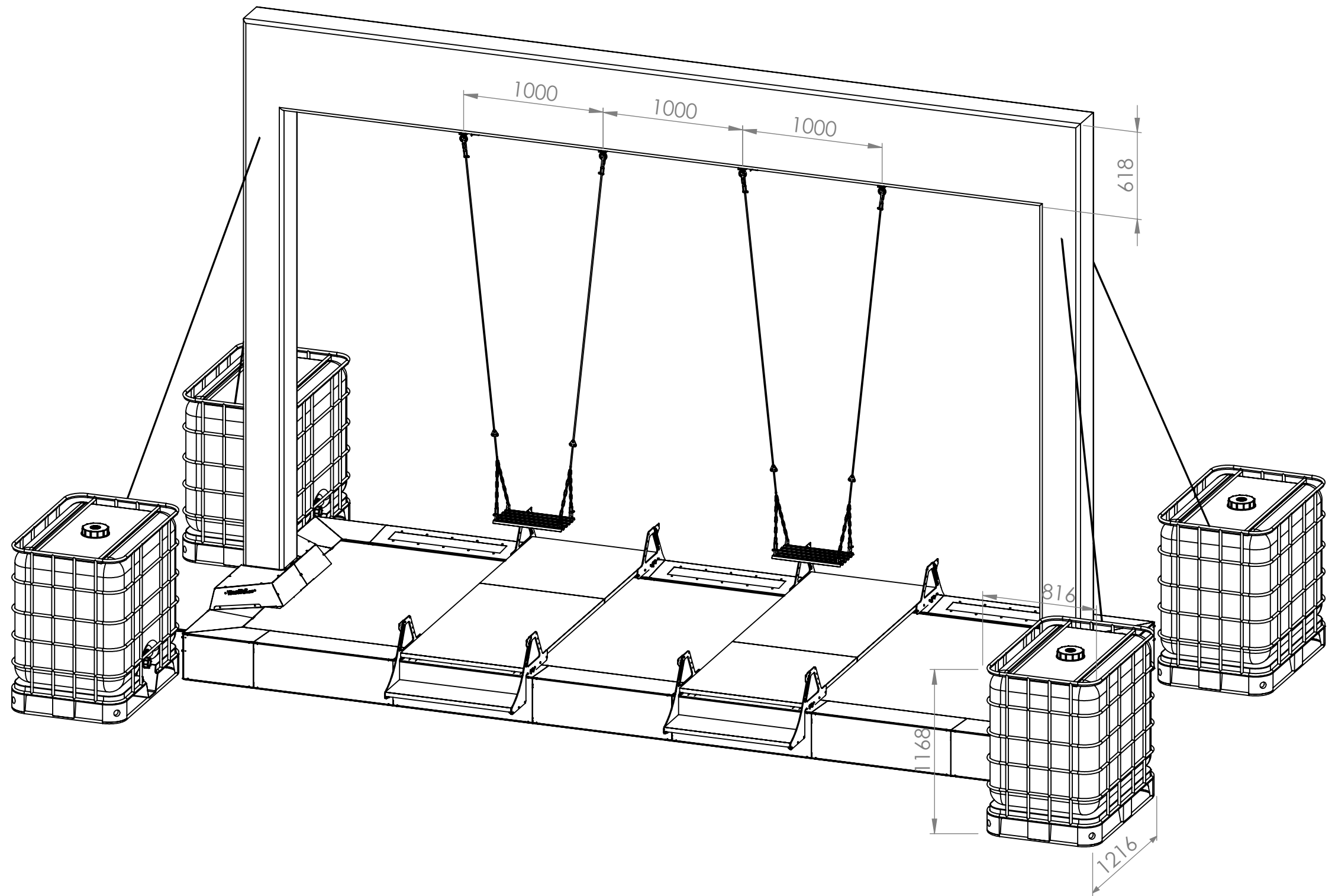

Tanks may be covered/branded by the client. Sizes may vary.

COMPANY:  Wordfall Ul. Szczygłów 30 44-200 Rybnik		DO NOT SCALE DRAWING		REVISION	
DRAWN		NAME		TITLE	
CHK'D		Wordfall		Two swings for exterior use	
APPV'D		TEL.		PART NO	
		+48601296649		WFL-KK-A0001-12	
MATERIAL:		SURFACE FINISH		DESCRIPTION	
				Mobile Installation	
		THICKNESS		BEND RADIUS	
		mm		mm	
		WEIGHT		A3	
		g			
		SCALE:1:30		SHEET 8 OF 19	

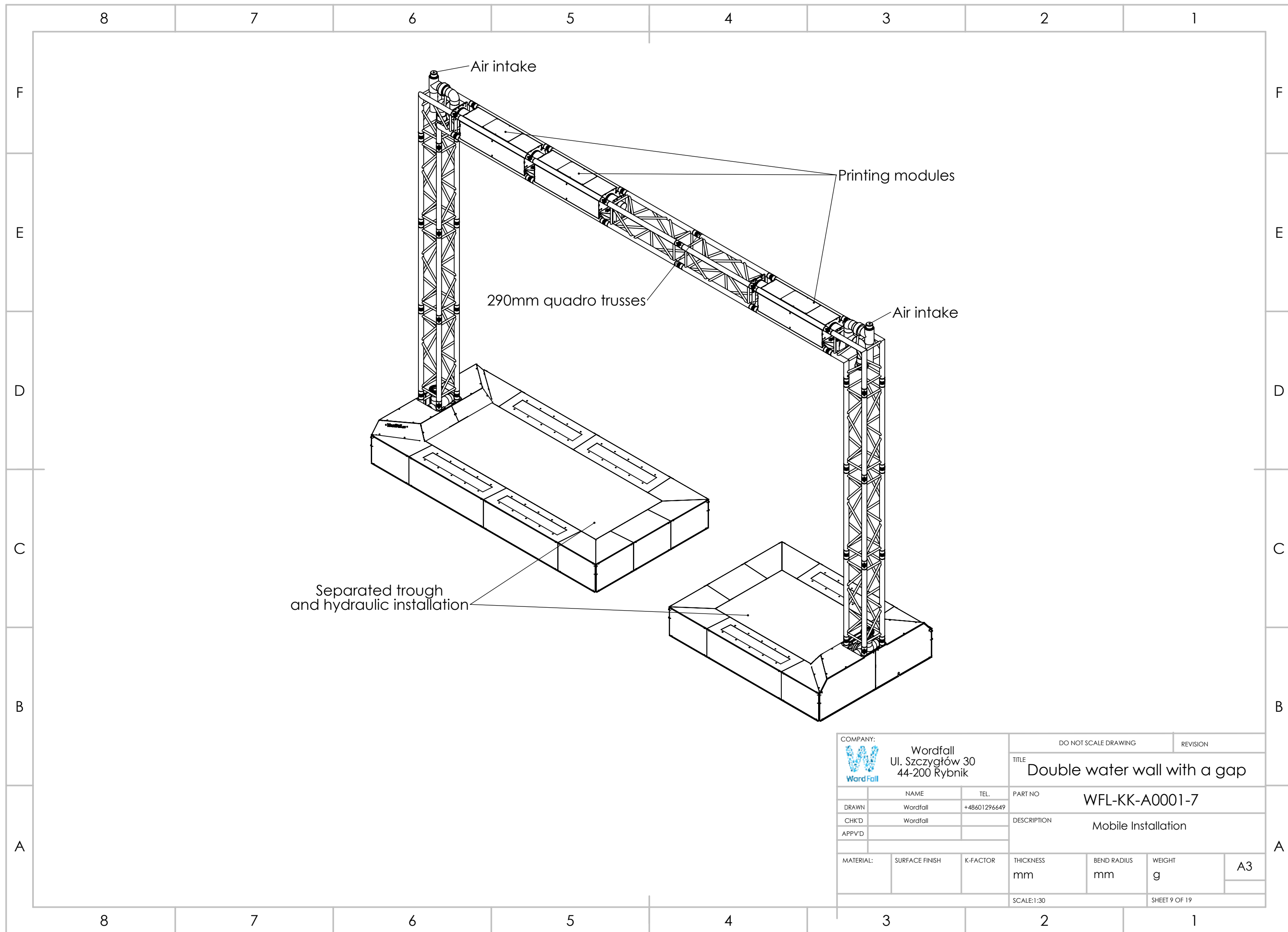

COMPANY:  Wordfall Ul. Szczygłów 30 44-200 Rybnik			DO NOT SCALE DRAWING		REVISION	
			TITLE: Double water wall with a gap			
			PART NO: WFL-KK-A0001-7			
DRAWN: Wordfall			TEL: +48601296649			
CHK'D: Wordfall			DESCRIPTION: Mobile Installation			
APPV'D:						
MATERIAL:	SURFACE FINISH	K-FACTOR	THICKNESS mm	BEND RADIUS mm	WEIGHT g	A3
			SCALE: 1:30		SHEET 9 OF 19	

Number of modules x 1000 + 2000 (gap) + 1027
 e.g. 3 modules, 2000 gap = 6027

Construction height: 2002 - 6002, rounded to 500
 e.g. 4002

1st water area
 e.g. 2 modules = 2000

2nd water area
 e.g. 1 module = 1000

Gap - 1016
 e.g. Gap 2000 = 984mm

1529

COMPANY:		Wordfall Ul. Szczygłów 30 44-200 Rybnik		DO NOT SCALE DRAWING		REVISION	
DRAWN		Wordfall		TITL		Double water wall with a gap	
CHK'D		Wordfall		PART NO		WFL-KK-A0001-7	
APPV'D				DESCRIPTION		Mobile Installation	
MATERIAL:		SURFACE FINISH		K-FACTOR		THICKNESS	
						mm	
				BEND RADIUS		WEIGHT	
				mm		g	
				SCALE:1:30		SHEET 10 OF 19	
						A3	

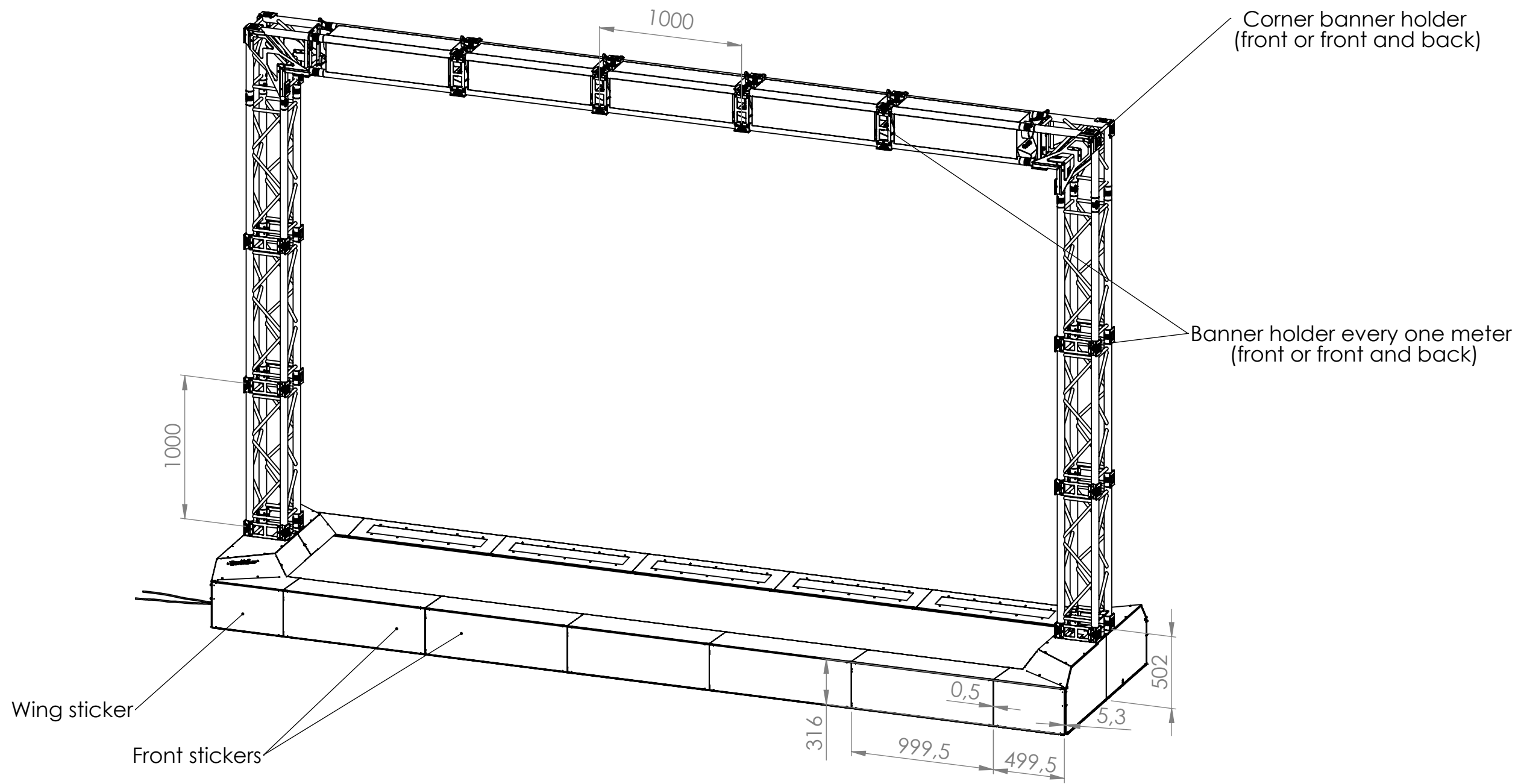

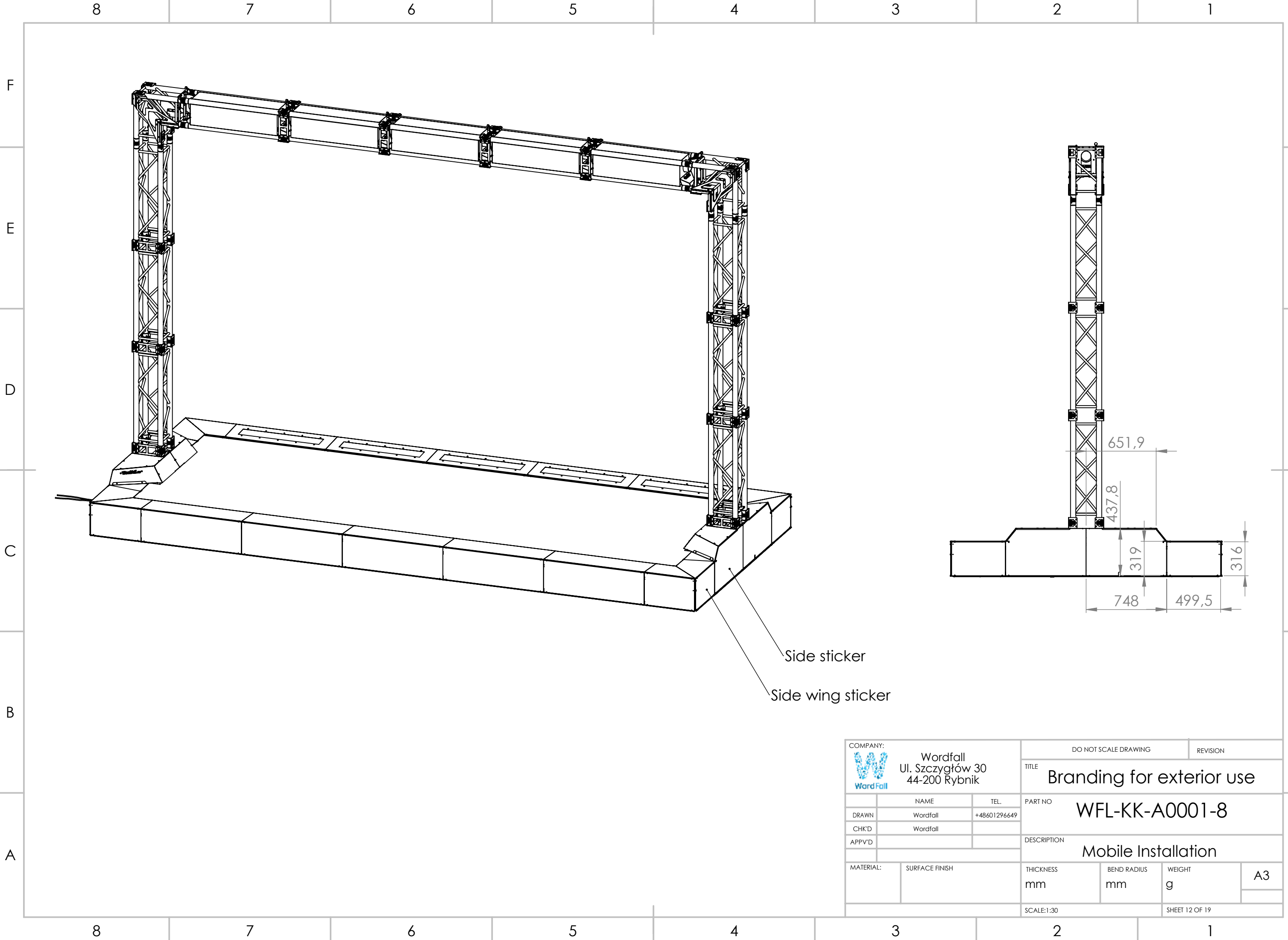

COMPANY:		Wordfall Ul. Szczygłów 30 44-200 Rybnik		DO NOT SCALE DRAWING		REVISION	
DRAWN		Wordfall		TITILE		Branding for interior use	
CHK'D		Wordfall		PART NO		WFL-KK-A0001-7	
APPV'D				DESCRIPTION		Mobile Installation	
MATERIAL:		SURFACE FINISH		THICKNESS		BEND RADIUS	
				mm		mm	
				WEIGHT		g	
				SCALE:1:30		SHEET 11 OF 19	
						A3	



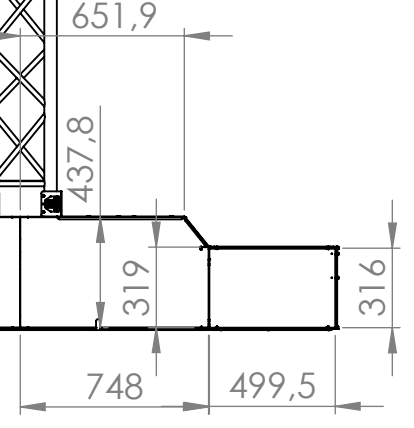

Side sticker

Side wing sticker

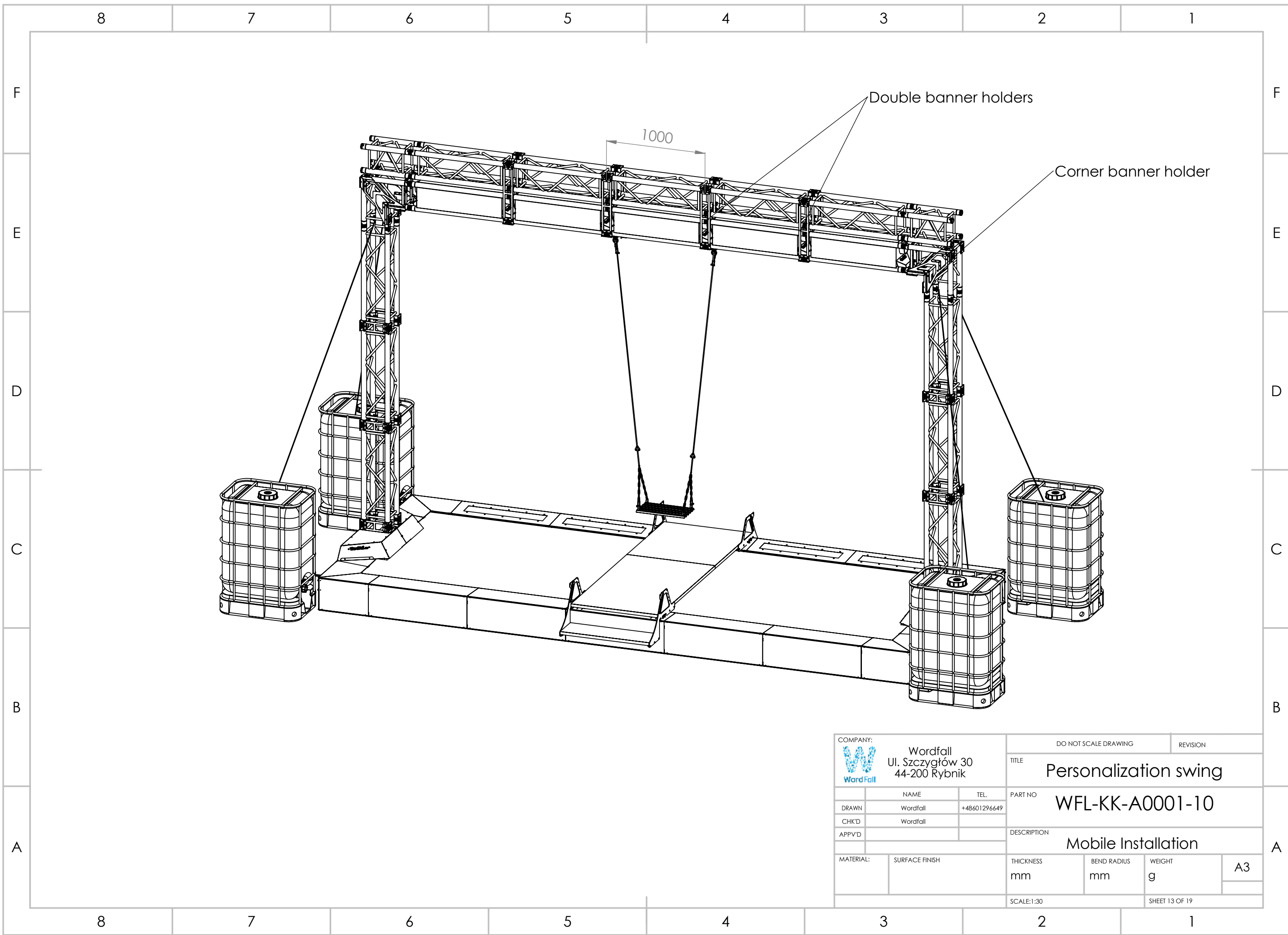

COMPANY:  Wordfall Ul. Szczygłów 30 44-200 Rybnik		DO NOT SCALE DRAWING		REVISION	
		TITLE Branding for exterior use			
		PART NO WFL-KK-A0001-8			
		DESCRIPTION Mobile Installation			
MATERIAL:		SURFACE FINISH		THICKNESS mm	BEND RADIUS mm
				WEIGHT g	A3
				SCALE:1:30	
				SHEET 12 OF 19	



COMPANY:  Wordfall Ul. Szczygłów 30 44-200 Rybnik		DO NOT SCALE DRAWING		REVISION	
DRAWN: Wordfall		TEL: +48601296649		TITLE: Personalization swing	
CHK'D: Wordfall		APPV'D:		PART NO: WFL-KK-A0001-10	
MATERIAL:		SURFACE FINISH:		DESCRIPTION: Mobile Installation	
THICKNESS: mm		BEND RADIUS: mm		WEIGHT: g	
SCALE: 1:30		SHEET 13 OF 19		A3	

There are two ways to fix a banner

1. Slide-in (only horizontal banners)
2. Using screws (both horizontal and vertical)

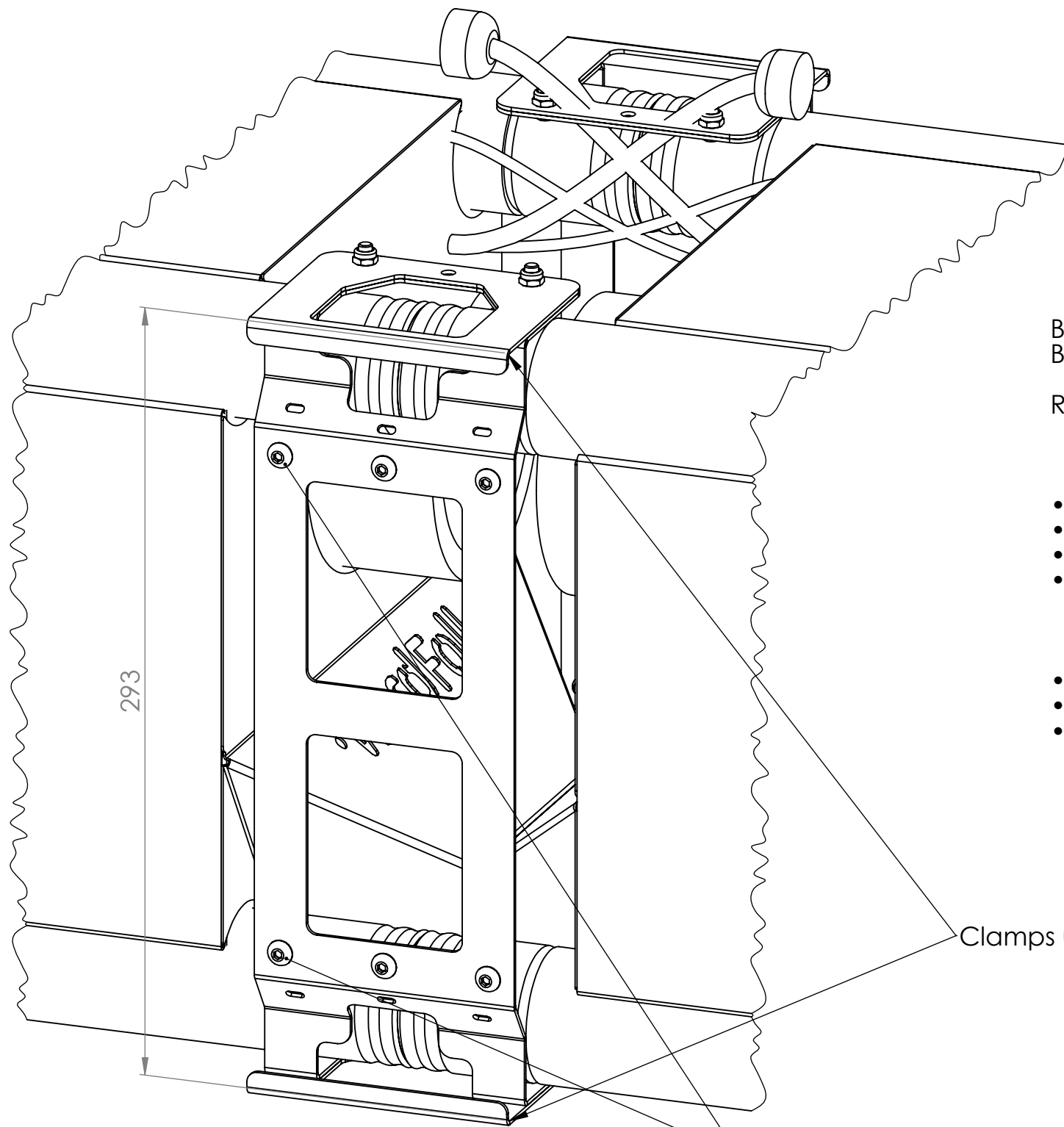

Banners and stickers should be delivered by the client
 Banners can be placed on the front side or front and back side

Requirements:

Slide-in banner:

- Thickness: 3-5mm
- Height: 290mm +/-2mm
- Length: total length of the construction
- No holes necessary

Screw-fixed banner:

- Any reasonable height and shape
- Weight: 1,5kg per banner holder
- Holes diameter: 6-7mm, holes should be already drilled before the installation. Our technicians will not be equipped to drill holes at the place

Clamps used only for slide-in banners

M5 screws used only for screw-fixed banner

COMPANY:  Wordfall Ul. Szczygłów 30 44-200 Rybnik		DO NOT SCALE DRAWING		REVISION	
DRAWN		NAME		TITLE	
CHK'D		TEL.		Standard banner holder	
APPV'D		PART NO		WFL-KK-A0001-7	
MATERIAL:		DESCRIPTION		Mobile Installation	
SURFACE FINISH		THICKNESS		BEND RADIUS	
		mm		mm	
		WEIGHT		A3	
		g			
		SCALE:1:2		SHEET 14 OF 19	

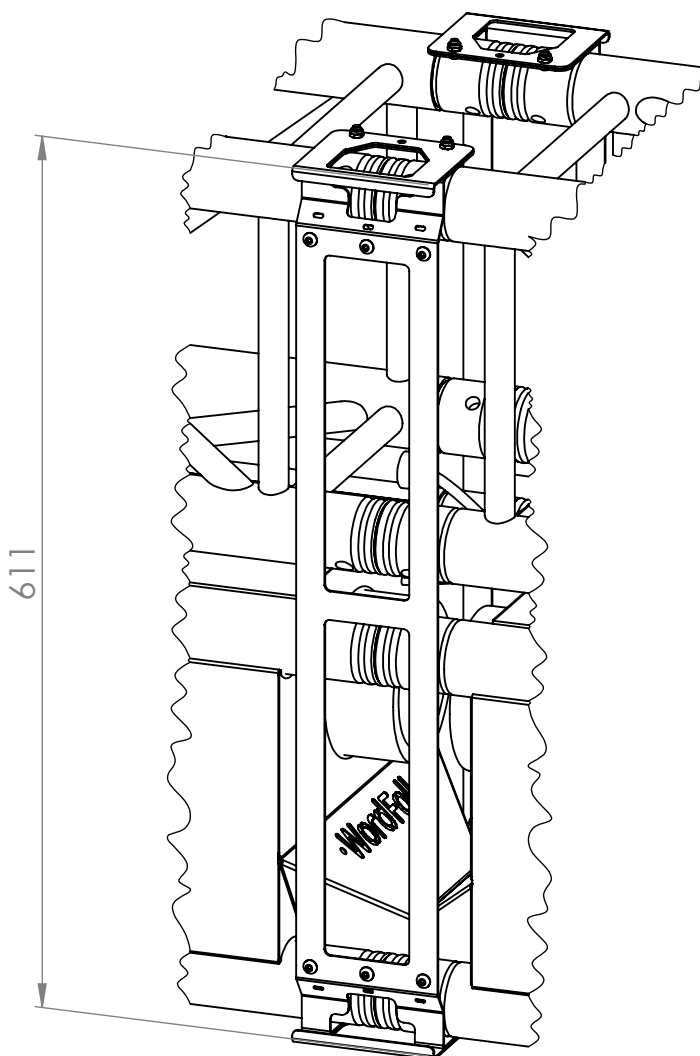

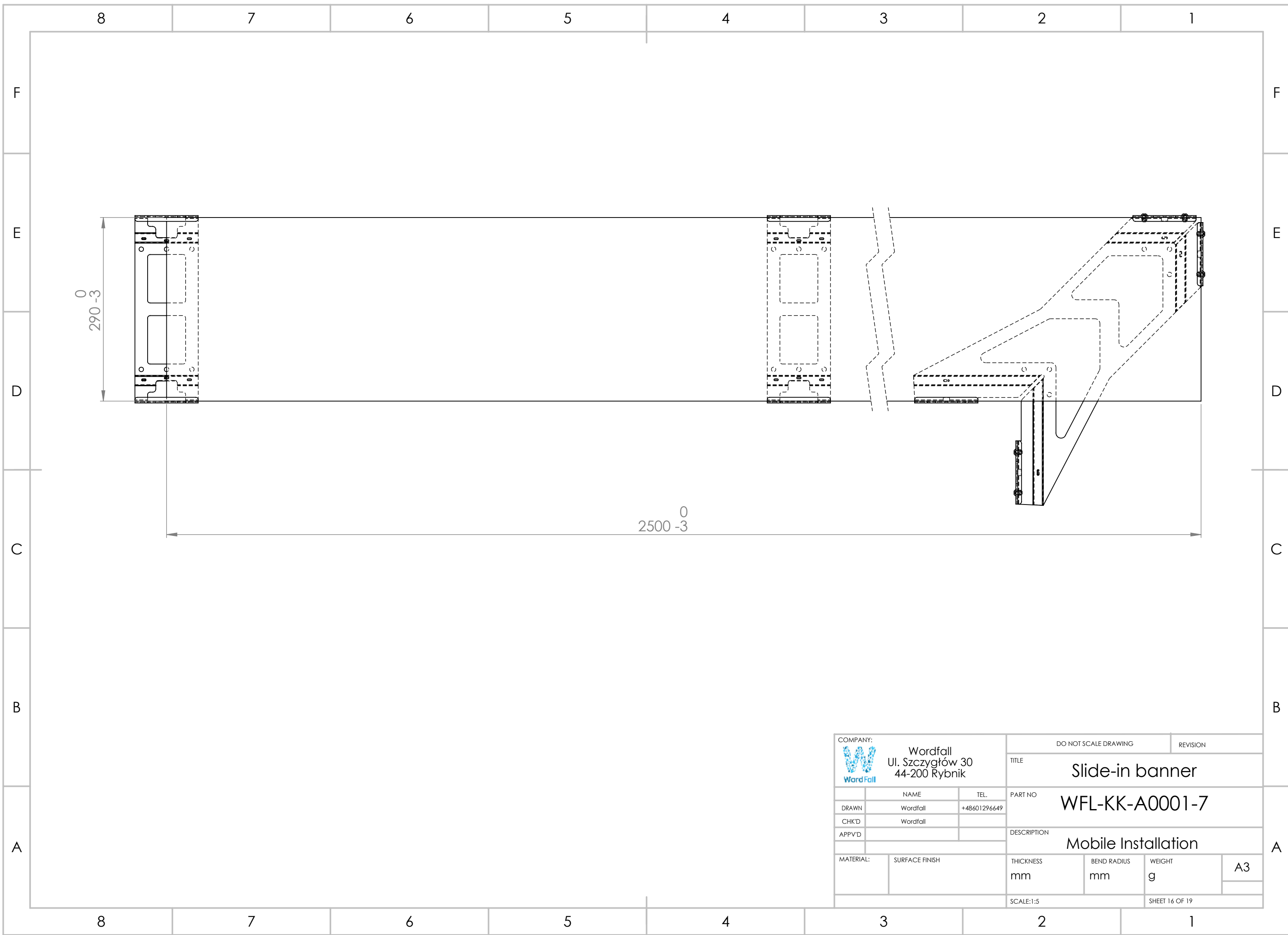

611

COMPANY:  Wordfall Ul. Szczygłów 30 44-200 Rybnik		DO NOT SCALE DRAWING		REVISION	
		TITLE Double banner holder			
		PART NO WFL-KK-A0001-10			
		DESCRIPTION Mobile Installation			
MATERIAL:		SURFACE FINISH		THICKNESS	BEND RADIUS
				mm	mm
				WEIGHT	A3
				g	
				SCALE:1:5	
				SHEET 15 OF 19	

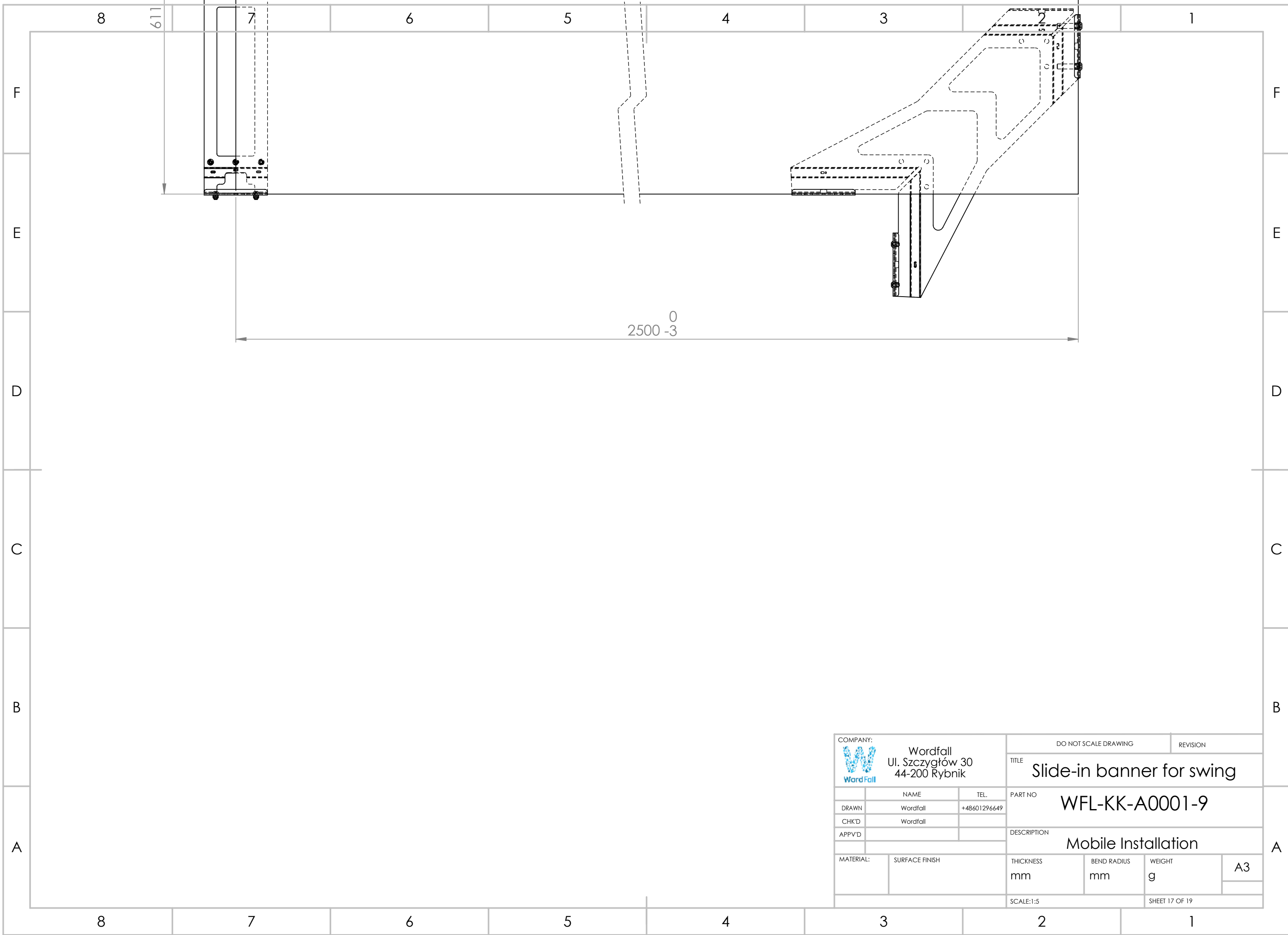

COMPANY:  Wordfall Ul. Szczygłów 30 44-200 Rybnik		DO NOT SCALE DRAWING		REVISION	
		TITLE Slide-in banner			
		PART NO WFL-KK-A0001-7			
		DESCRIPTION Mobile Installation			
DRAWN	NAME	TEL.	THICKNESS	BEND RADIUS	WEIGHT
Wordfall	Wordfall	+48601296649	mm	mm	g
CHK'D	Wordfall				A3
APPV'D					
MATERIAL:	SURFACE FINISH		SCALE:1:5	SHEET 16 OF 19	



COMPANY:  Wordfall Ul. Szczygłów 30 44-200 Rybnik		DO NOT SCALE DRAWING		REVISION	
		TITLE Slide-in banner for swing			
		PART NO WFL-KK-A0001-9			
		DESCRIPTION Mobile Installation			
MATERIAL:	SURFACE FINISH	THICKNESS mm	BEND RADIUS mm	WEIGHT g	A3
		SCALE:1:5		SHEET 17 OF 19	

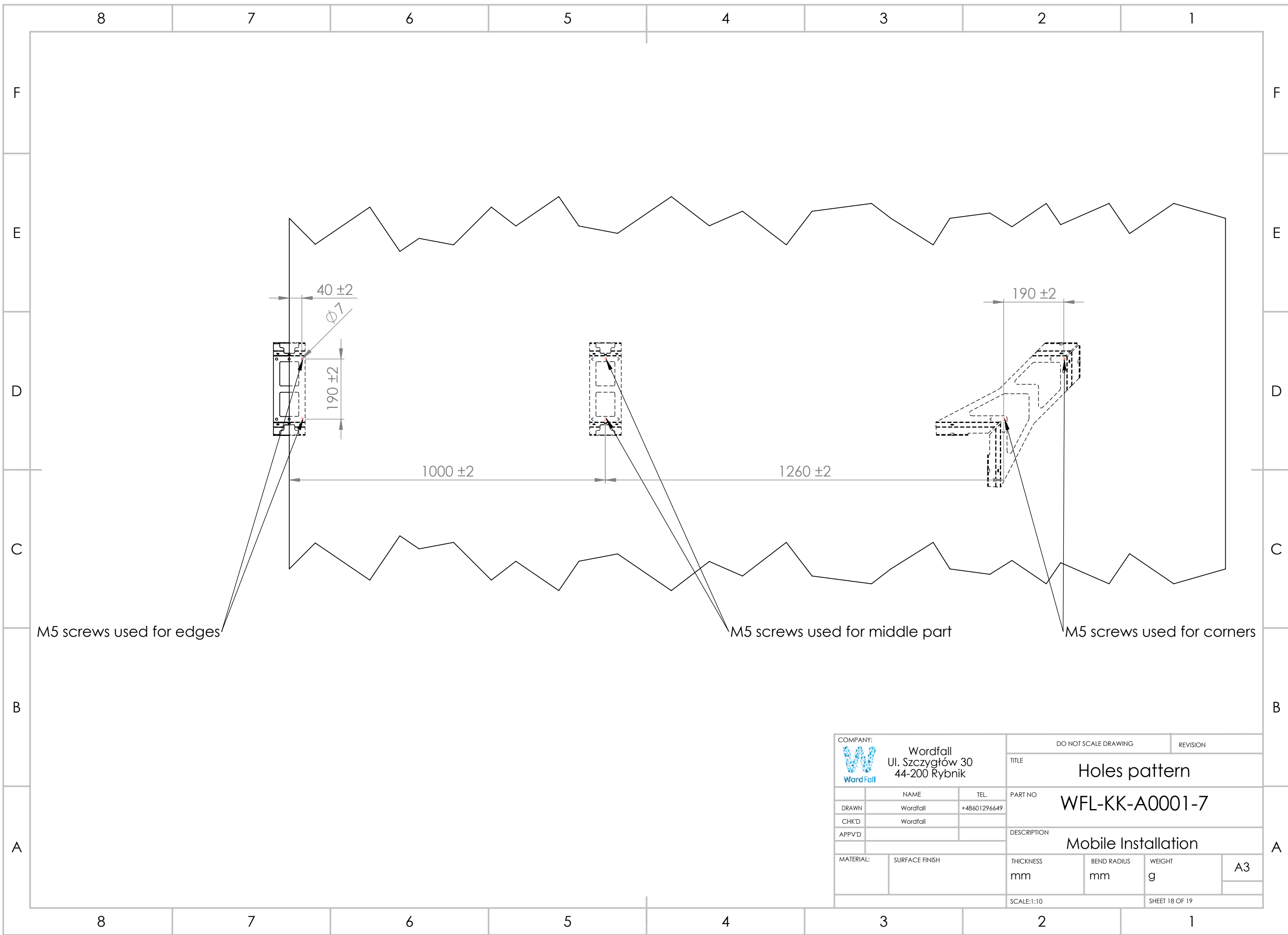



M5 screws used for edges

M5 screws used for middle part

M5 screws used for corners

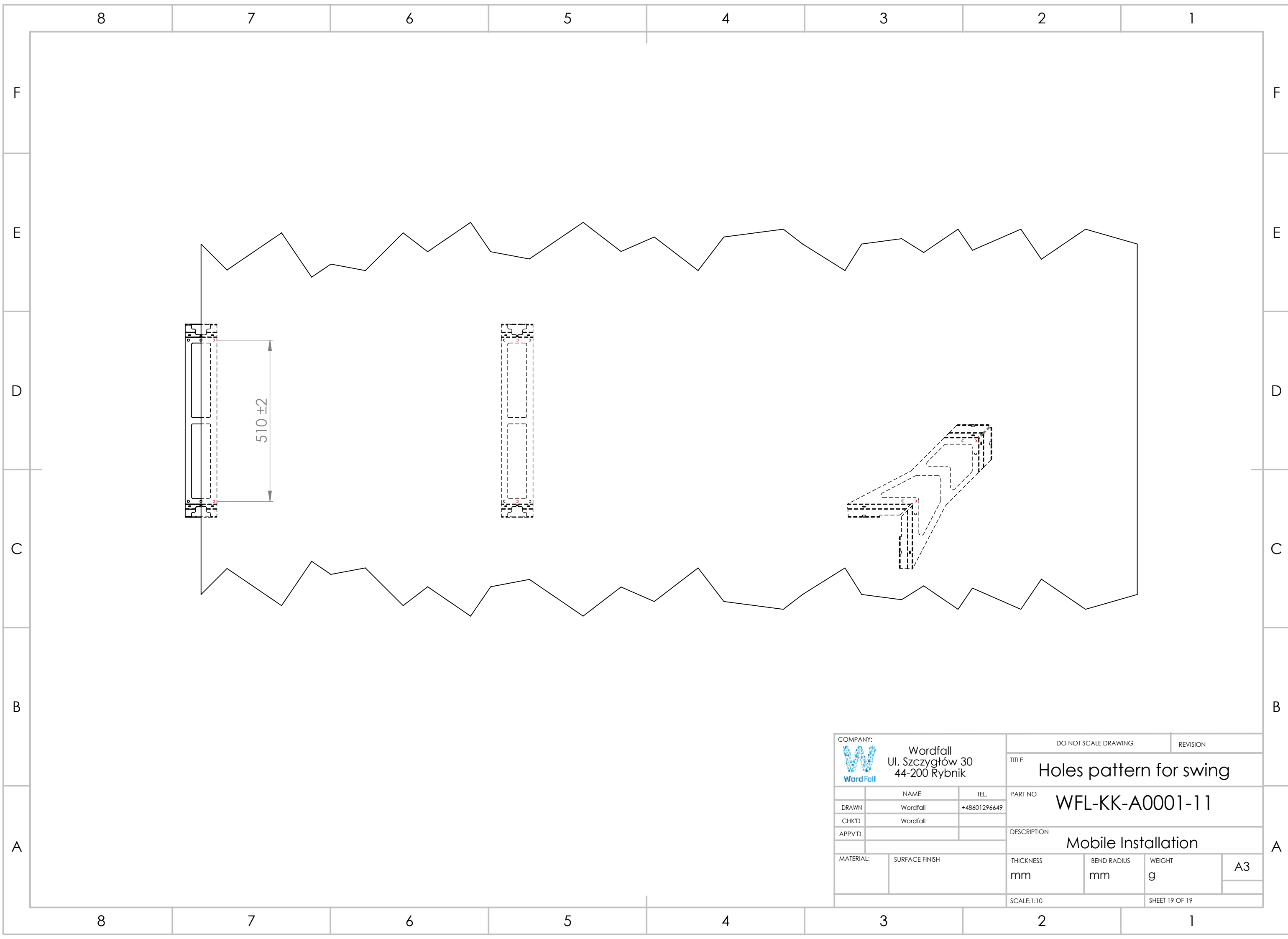
COMPANY:  Wordfall Ul. Szczygłów 30 44-200 Rybnik		DO NOT SCALE DRAWING		REVISION	
		TITLE Holes pattern			
		PART NO WFL-KK-A0001-7			
		DESCRIPTION Mobile Installation			
MATERIAL:	SURFACE FINISH	THICKNESS mm	BEND RADIUS mm	WEIGHT g	A3
		SCALE:1:10		SHEET 18 OF 19	



COMPANY:  Wordfall Ul. Szczygłów 30 44-200 Rybnik		DO NOT SCALE DRAWING		REVISION	
		TITLE: Holes pattern for swing			
		PART NO: WFL-KK-A0001-11			
		DESCRIPTION: Mobile Installation			
MATERIAL:	SURFACE FINISH	THICKNESS: mm	BEND RADIUS: mm	WEIGHT: g	A3
		SCALE: 1:10		SHEET 19 OF 19	